

Technical Manual



PRIMA *plank*TM

Contents

PRIMA^{plank}™

Designed to attain pure luxury

Aesthetic Cladding | Decorative Fencing | Gable End Cladding | External Wall Cladding | Fascia Board

1. Introduction	02
1.1 General	
1.2 Applications	
1.3 Features & Benefits	
1.4 Tests and Certification	
2. General Fixing Instructions	02
2.1 Material Selection	
2.2 Framing Specification	
2.3 Batten Specification	
2.4 Fasteners	
2.5 Sealing Joints & Gaps	
2.6 Jointing Against Other Materials	
3. External Wall & Gable End Cladding	03
3.1 General	
3.2 Framing Construction	
3.3 Flashing	
3.4 Sarking	
3.5 Plank Overlaps	
3.6 Installation Procedures	
3.7 Fixing to Timber	
3.8 Fixing to Steel	
3.9 Joints	
3.10 Ground Clearance	
3.11 Corners	
3.12 Details at Openings	
4. Cladding to Masonry Wall	06
4.1 General	
4.2 Battening Requirement	
4.3 Installation Method	
4.4 Sarking	
4.5 Jointing	
4.6 Corners	
4.7 Openings	
4.8 Wall to Eaves Junction	
5. Fascia Board	08
5.1 General	
5.2 Support	
5.3 Installation	
5.4 Joints	
6. Decorative Fencing	09
6.1 General	
6.2 Framing Requirement	
6.3 Installation	
7. Finishes Recommendation	10
8. Working Instructions	10
8.1 Cutting	
8.2 Drilling	
8.3 Handling & Storage	

1 Introduction

1.1 General

PRIMAplank™ is an autoclaved cellulose fibre reinforced cement siding board manufactured by Hume Cemboard Industries Sdn Bhd, an MS ISO 9001:2000 accredited company. Manufactured from Portland cement, cellulose fibre, finely ground sand and water, **PRIMAplank™** has become extremely popular when a relatively maintenance free timber planking appearance is desired.

1.2 Applications

PRIMAplank™ is designed for external applications where superb weatherability and long-lasting durability form part and parcel of performance criteria. These applications includes:-

- External wall cladding
- Gable end cladding
- Cladding to masonry wall
- Fascia board
- Decorative fencing

PRIMAplank™ is used where there is a requirement for traditional timber look and to add character and depth to flat mundane surfaces.

1.3 Features & Benefits

- Natural timber look (Woodgrain)
- Weather resistant
- Will not rust or rot
- Termite resistant
- Does not warp or twist
- Fire resistant- Class '0'

1.4 Tests and Certification

PRIMAplank™ has been approved by Fire and Rescue Department, Malaysia as a Class '0' building material under the Malaysian Uniform Building By-law 1984.

PRIMAplank™ has been tested in accordance with BS 476; Fire tests on building material and structure. The test results are as follows:-

1.4.1 Serviceable Life

When installed and maintained as per good building practice and specifications described in this manual, **PRIMAplank™** is expected to have serviceable life of 50 years.

1.4.2 Standard Sizes and Mass

PRIMAplank™ comes in standard thickness of **7.5mm**. It is available in two patterns:



PRIMAplank™ - Woodgrain
has a texture on the front surface



PRIMAplank™ - Smooth
is available with a flat unsanded surface

Approximate masses at Equilibrium Moisture Content of 7%, at temperature of 27°C ± 2°C and relative humidity of 65% to 95% are:-

Thickness x Width x Length	Approximate Mass per Piece
Smooth & Woodgrain	
• 7.5mm x 230mm x 4200mm	10.6kg
• 7.5mm x 300mm x 4200mm	13.8kg

2 General Fixing Instructions

2.1 Material Selection

PRIMAplank™ thickness should be selected based on the intended applications. For general cladding, fascia board and fencing applications, **7.5mm** thick plank is adequate.

Trimming plank to a size less than the standard width will reduce its capacity to withstand loads. In instances where reduced-width planks are desirable such as for fencing application, always refer to Hume Cemboard before specifying or applying them.

Do not apply **PRIMAplank™** in areas where it remains in contact with standing water.

2.2 Framing Specification

PRIMAplank™ can be applied to **timber** or **light gauge** steel framing members. Construction shall be in accordance with local building practice.

Framing components must have adequate durability for the intended use. These durability criteria shall among others include resistance to weather; corrosion and pest (i.e. termite attack).

Framing timber should be thoroughly dry and selected to minimize shrinkage when planks are installed.

Steel framing must be fabricated from cold-formed galvanized light gauge steel of a minimum **0.55mm** to **1.60mm** base metal thickness.

As the straightness of finished wall is highly dependent on workmanship of framework, best result can be achieved when frame straightness is between **3mm** to **4mm** in any **3000mm** length.

2.3 Batten Specification

Thick hot rolled structural steel sections and masonry wall must be battened prior to installation of **PRIMAplank™** cladding.

Use **timber batten** with a minimum of **25mm** thick x **50mm** wide to allow adequate nail penetration.

Steel battens must have a minimum **35mm** face width. They are typically 'Z' or top hat sections. Use only **galvanised light gauge steel** of a minimum **0.55mm** to **1.55mm** base metal thickness.

2.4 Fasteners

Select the appropriate type of fasteners based on the type of framing. Fasteners should have acceptable level of durability and be suitably coated for the intended application.

PRIMAplank™ can be fixed by **hand nailing** or **air gun nailing**. For **screw fixing**, use **screw gun** with high torque and variable speed of zero to **2,500 revolution per minute** fitted with a depth control attachment.

Nail head should finish flush with the **PRIMAplank™** face and avoid overdriving.

Drive screw slightly below the plank face and cover fastener head with exterior grade cementitious patching compound. Smoothen with sandpaper if necessary before painting.

2.5 Sealing Joints and Gaps

Gaps at plank joints, corners and openings must be sealed with flexible/ paintable polyurethane sealant. Sealant must be compatible with cementitious panel products. Apply **masking tape** at both plank edges and start filling the bottom edge and squeezing the sealant in the upward direction. Use **spatula** to smoothen and remove any excess sealant. Remove masking tape immediately upon completion. Sealant manufacturer's instruction must be adhered to. Sealant must only be painted as recommended by the manufacturer.

2.6 Jointing Against other Material

When butt jointing **PRIMAplank™** and other building materials such as masonry wall, a minimum of **6mm** gap must be provided. Seal gap with paintable/ flexible sealant, as shown in **Figure 1**.

Table: Fastener Specification

Fasteners to Timber



2.8mm Ø x 40mm Wire Nails

Fasteners to Steel



Steel thickness 0.55mm to 0.75mm
No. 8 x 32mm Self-embedding head, self-drilling Screws



Steel thickness 0.8mm to 1.6mm
No. 8 x 32mm Self-embedding head, self-drilling "Wing Tek" Screws

Note:

1. Drive nail head snug or flush with plank face.
2. Pre-drilling is required when nailing between 20mm to 50mm from the plank end.
3. Drive screw heads not more than 1mm below plank face.
4. Overdriven fastener point should be cover with exterior grade cementitious patching compound before painting.
5. Hold plank firmly against the frame while driving the fasteners.

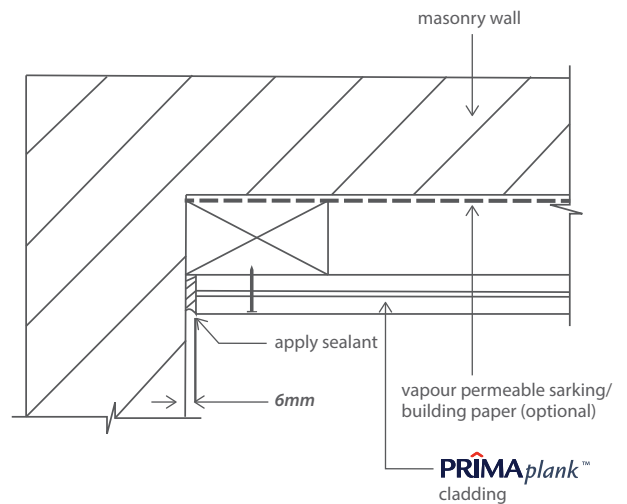

Figure 1: Jointing with other material

3 External Wall & Gable End Cladding

3.1 General

PRIMAplank™ is suitable for general wall cladding application when a lightweight wall system is preferred. The usage includes construction of new buildings such as residential dwellings and resorts. In addition, **PRIMAplank™** can also be used for renovation/ extension of existing buildings especially in the construction of upper storey.

3.2 Framing Construction

PRIMAplank™ must be supported at 600mm maximum centres. Refer **Figure 2**. The minimum stud face width shall be as follows:-

- Timber framing - 50mm min.
- Steel framing - 35mm min.

Timber framing is typically 50mm x 75mm and light-gauge metal framing is typically 35mm x 64mm x 0.55mm BMT.

When on-stud jointing is preferred, stud face width must be increased to provide for adequate edge fixing distance. Use **frame off-cuts** to **pack stud** at plank joint if required.

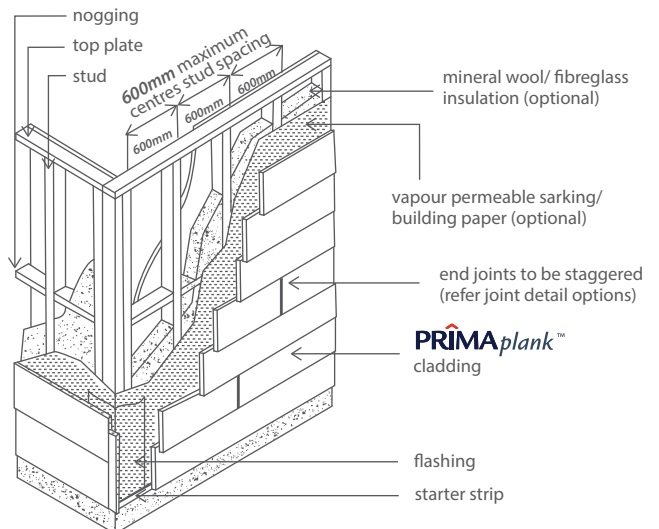

Figure 2: Horizontal planking

3.3 Flashing

When applied as external wall cladding it is a good building practice to apply flashing material at corners, above the **head** and **under the sill of an opening**.

3.4 Sarking

During windy condition, the external pressure would generally be greater than the building's internal pressure. The pressure differential will likely draw water into the wall cavity through the plank's joints and laps. It is recommended to install **vapour permeable sarking** between **PRIMAplank™** and the framing surface. The use of **reflective sarking** will enhance the thermal insulation property of the cladding system.

3.5 Plank Overlaps

For external cladding applications, plank must overlap the previous course by a **minimum of 25mm**. Plank overlap may be increased to achieve the desired exposed plank surface. Higher overlaps may also improve the weatherproofing of a framed-wall particularly when sarking material is not applied. When necessary, overlap may be increased to obtain full-course planking to match the wall height.

To facilitate plank installation with consistent overlaps, use a **lap gauge**. A lap gauge can be fabricated from **PRIMAplank™** off-cuts or timber piece. Refer **Figure 3**.

3.6 Installation Procedure

These steps provide a general guide for installation of **PRIMAplank™**:

1. Ensure framing is **true and align** prior to fixing **PRIMAplank™**.
2. Apply **building paper sarking** over the framework.
3. Fix **flashing** at all internal and external corner and heads of openings such as **door** and **window**.
4. Install **timber moulds** at internal and external corners.
5. Secure a **40mm wide PRIMAplank™** starter strip or treated timber strip along the bottom plate.
6. Use a **spirit level** to locate the top edge of the first course of the plank
7. Drive a series of **guide nails** around the **perimeter** of the timber framework to indicate the **top edge** of the first course of the plank.
8. Fix the first plank starting from the **external corner**. Set the **top edge** of the plank flush against the guide nails and the **end abutting** the (moderate contact) **timber corner stop**. Drive fastener to the **bottom plate** through the plank thickness and the starter strip at **200mm centres maximum**.
9. Fix the balance of the planks of the **first course** around the building. Planks may be joined with proprietor PVC jointer.
10. Provide a minimum of **25mm** overlap between each **successive** plank course. Measure the **total wall height** to be clad and calculate the suitable overlap so that a near **full-width** plank finishes at the **top of the clad wall**. Remove the guide nails and continue the next course of the plank with an off-cut plank. This is done to ensure that the plank joints would be **staggered between courses**.
11. Check **level** occasionally.

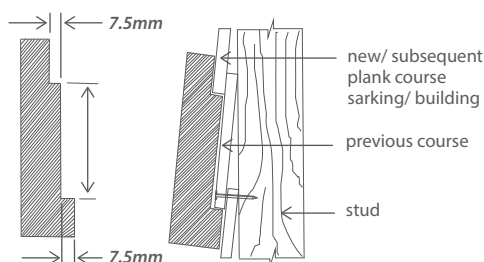

Figure 3:

Lap gauge

3.7 Fixing to Timber

When applied onto timber framing, **PRIMAplank™** must be nailed at centre of overlap through both thicknesses, as shown in **Figure 4**.

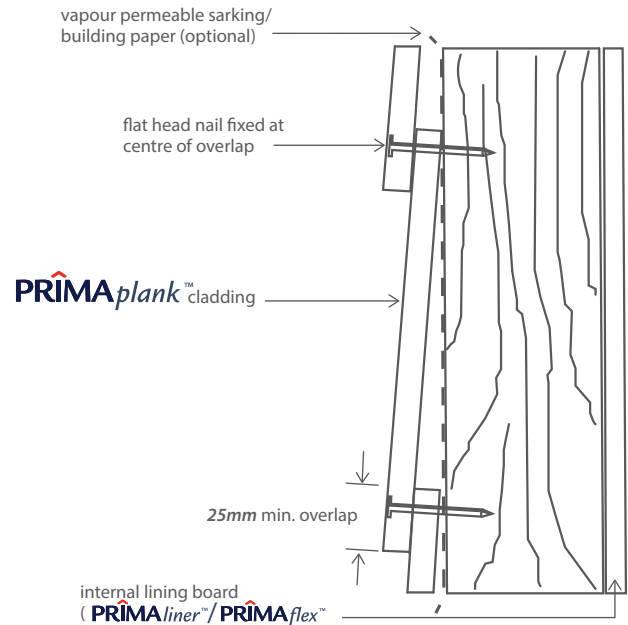

Figure 4: Fastening to timber frame

3.8 Fixing to Steel

Planks are screwed to **light gauge steel framing** through the top plank only. Refer **Figure 5**.

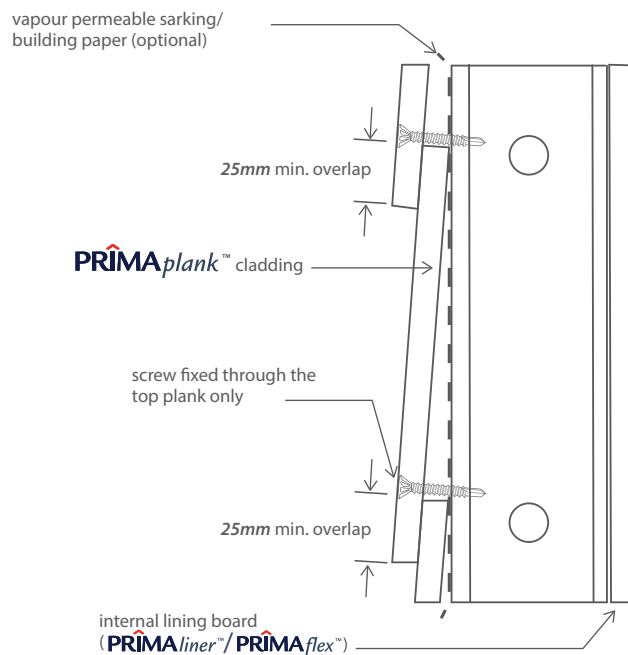

Figure 5: Fastening to steel frame

3.9 Joints

Joint options are shown below. When applied as **wall cladding**, plank joints should preferably be **staggered** between each plank course.

PRIMAplank™ "off-stud" jointing method incorporates proprietary **PVC jointer** between plank ends. Refer **Figure 6**.

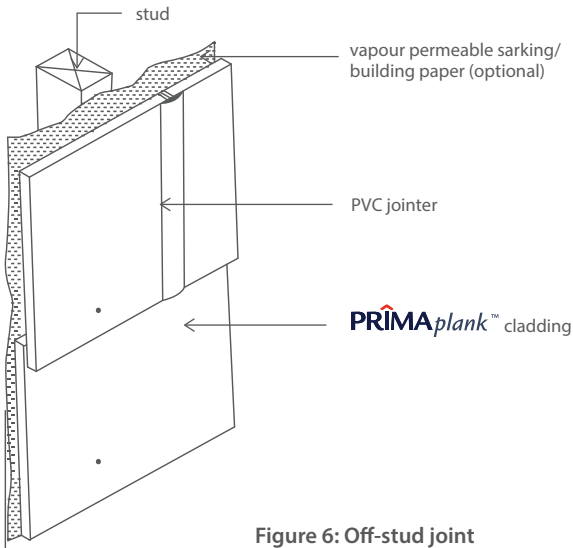

Figure 6: Off-stud joint

On-stud jointing can be done by **butt jointing** plank ends with moderate contact. Alternatively, provide a nominal **3mm** gap and seal joint with exterior grade paintable/ flexible sealant. Refer **Figure 7**.

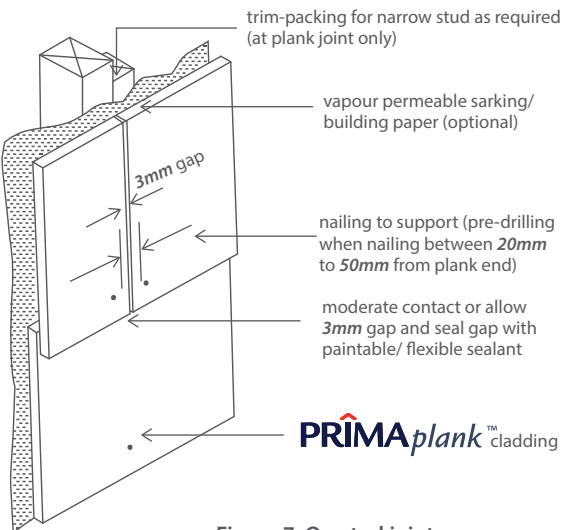

Figure 7: On-stud joint

3.10 Ground Clearance

Provide a minimum of **150mm** clearance between bottom edge of plank (or starter strip) and the earth as shown in **Figure 8**.

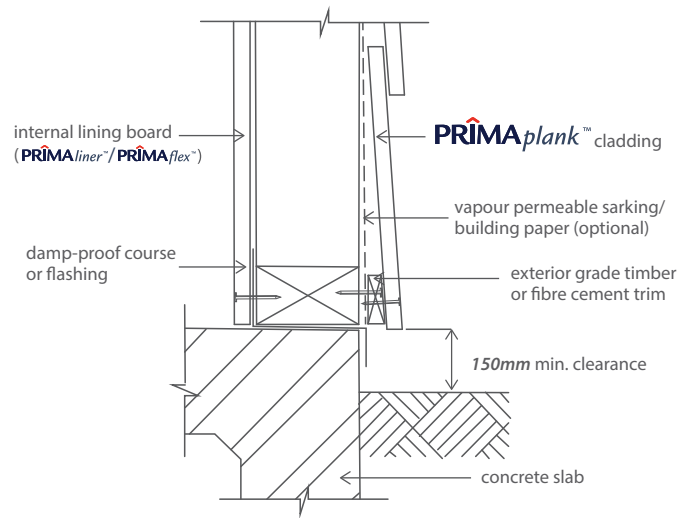

Figure 8: Ground Clearance

3.11 Corners

Internal and external corners may be finished with timber stops as illustrated in **Figure 9**.

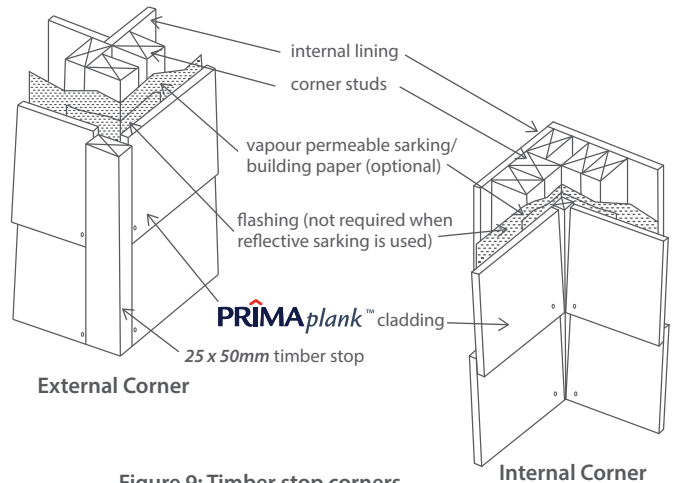

Figure 9: Timber stop corners

Alternatively, when timber posts are utilized, abutted to the side of the posts. Refer **Figure 10**.

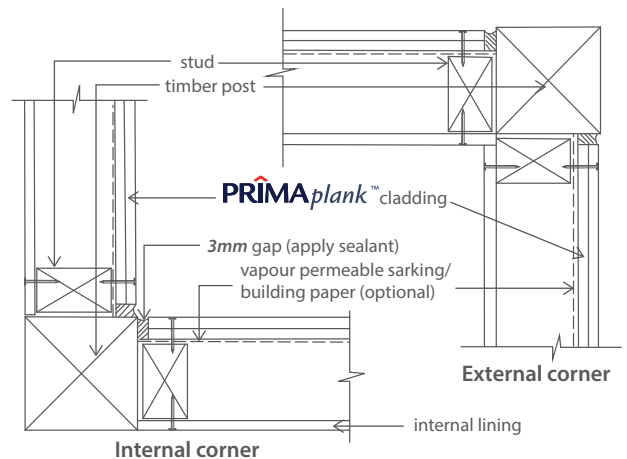

Figure 10: Timber post corners

3.12 Details at Openings

When applying plank at around **window** or **door openings**, allow an approximately **5mm clearance** at the **sill, jamb** and **head**. Seal gap with paintable/ flexible sealant. Do not apply sealant between **head flashing** and **plank edge**.

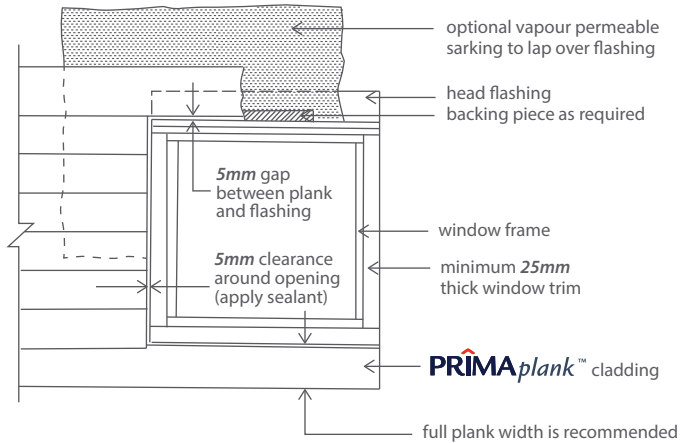

Figure 11: Window/ door opening detail

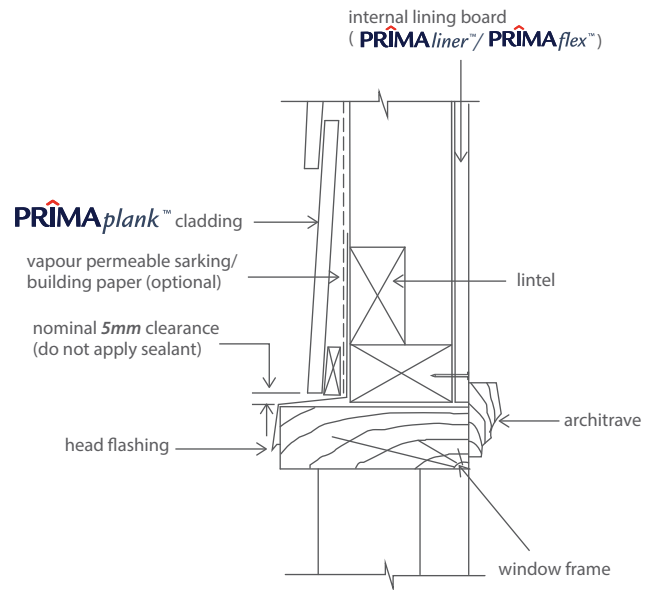

Figure 12: Head Flashing Detail

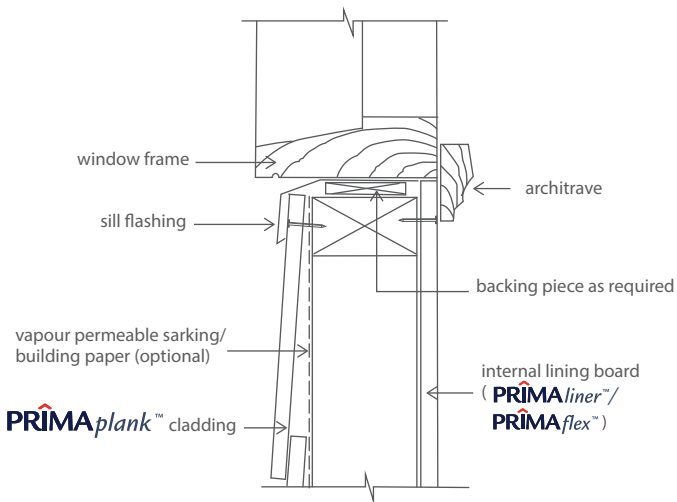

Figure 13: Sill Flashing Detail

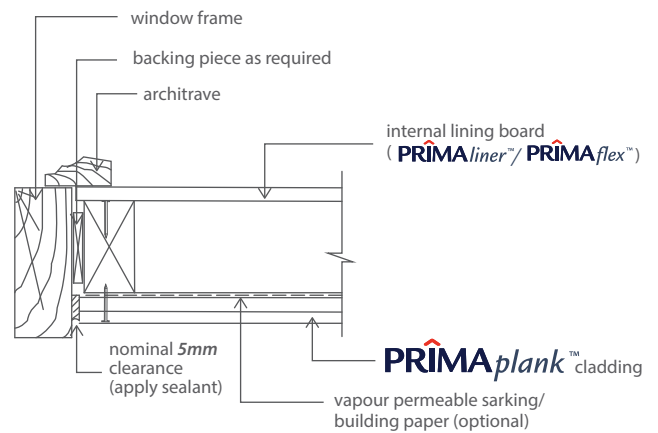

Figure 14: Door/ window jamb detail

4 Cladding To Masonry Wall

4.1 General

PRIMAplank™ can be clad onto masonry wall to enhance the aesthetic appearance of residential or commercial buildings.

4.2 Battening Requirement

Masonry wall must be battened prior to applying PRIMAplank™. Battens must be spaced vertically at **600mm** maximum centres. Ensure batten's straightness is within the acceptable tolerance. Battens must be adequately fastened onto the masonry wall.

4.3 Installation Method

PRIMAplank™ may be installed horizontally. In any case, support must be provided at **600mm** centres. Installation method is similar to that of external cladding application.

Battens can be applied directly onto relatively flat/ even masonry wall. Refer **Figure 15**.

Provide spacers or brackets when battening uneven masonry wall as shown in **Figure 16**. Alternatively, sub-framing may be installed horizontally to uneven surface at approximately **1500mm** maximum interval before securing the battens. All framing components must be adequately secured onto masonry wall. Consult a qualified engineer to verify structural adequacy if required.

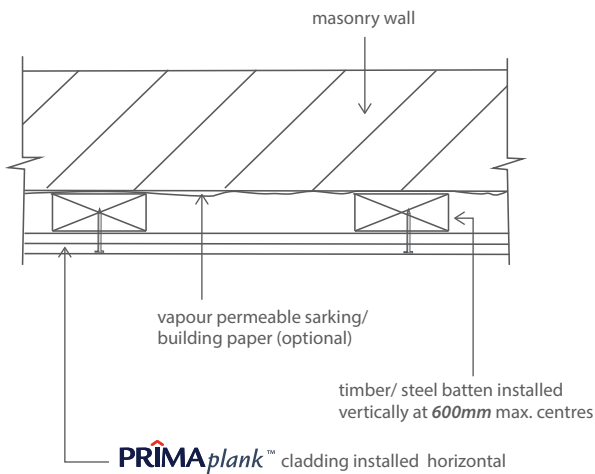

Figure 15: Battening onto flat masonry wall

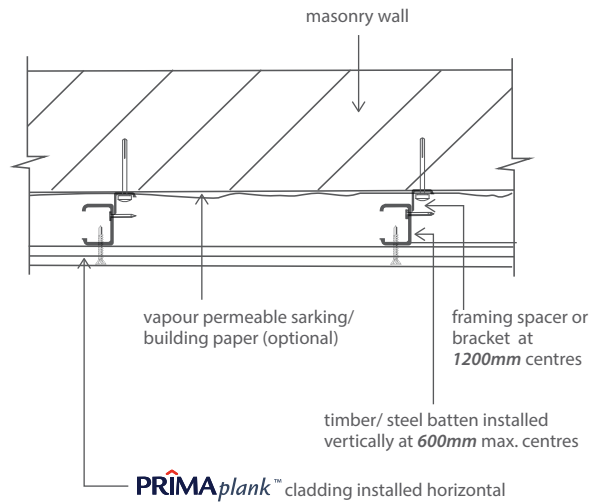

Figure 16: Battening onto uneven masonry wall

4.4 Sarking

It is recommended to install a **vapour permeable sarking** material on the masonry wall prior to fixing battens.

4.5 Jointing

Planks can be jointed with **PVC jointer** or **Butt Jointed**. These jointing methods are similar to the external cladding joints shown in **Figure 6 & 7**.

4.6 Corners

Internal and external corners can be decorated with exterior grade timber trim. Trim can also be fabricated using **PRIMAplank™** cladding, cut to the desired width. Refer Figure 17.

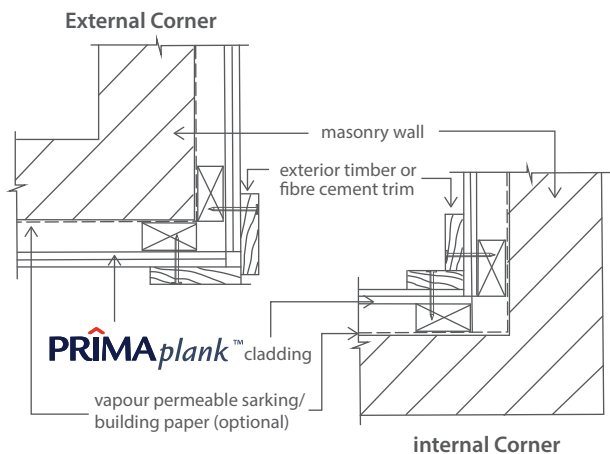

Figure 17: Corner details

4.7 Opening

Door or window opening may be finished with trims. Provide 5mm gap between **PRIMAplank™** and trims around the opening as described in **Figure 11**.

When desired, opening may be decorated with **in-situ concrete** or **pre-formed coping** as illustrated in **Figure 18, 19 and 20**.

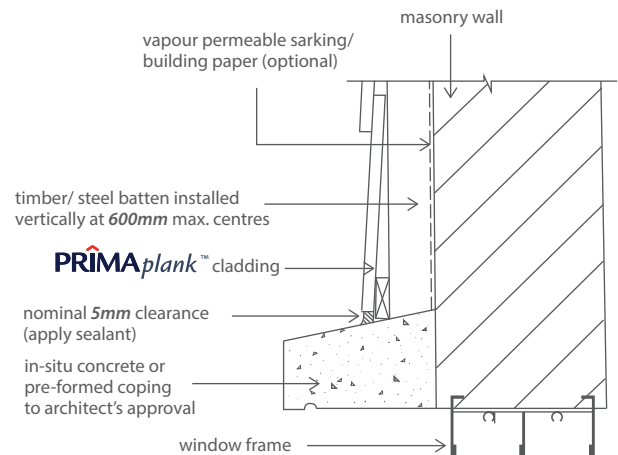

Figure 18: Window head detail

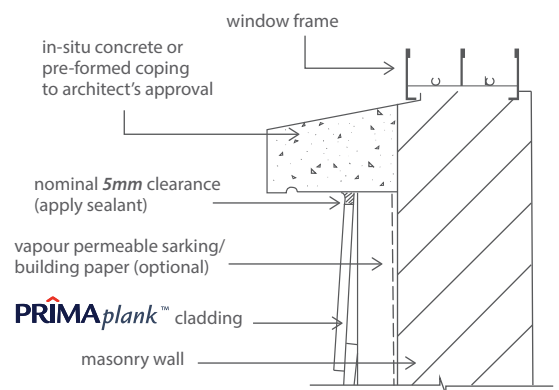

Figure 19: Window sill detail

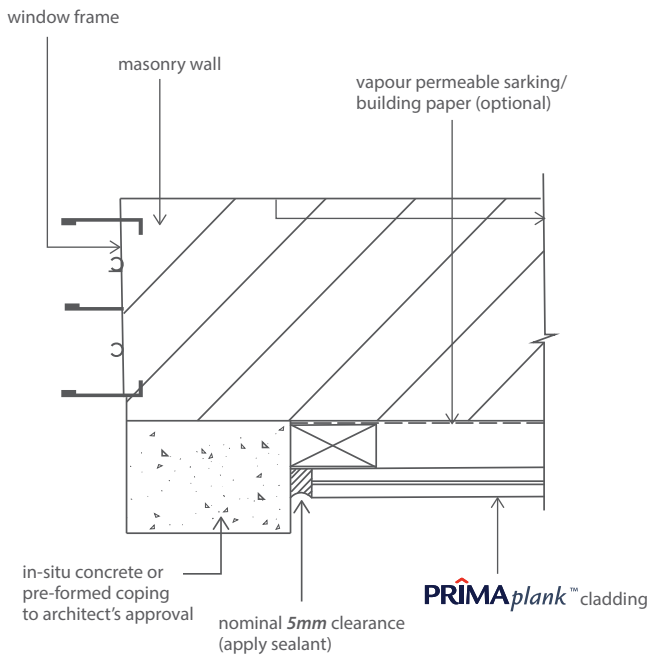

Figure 20: Window detail

4.8 Wall-to-Eaves Junction

Provide adequate ventilation between masonry wall and PRIMAplank cladding. The ventilation can either be provided through the roof or below the eaves. Ventilated path through the roof is depicted in Figure 21 below.

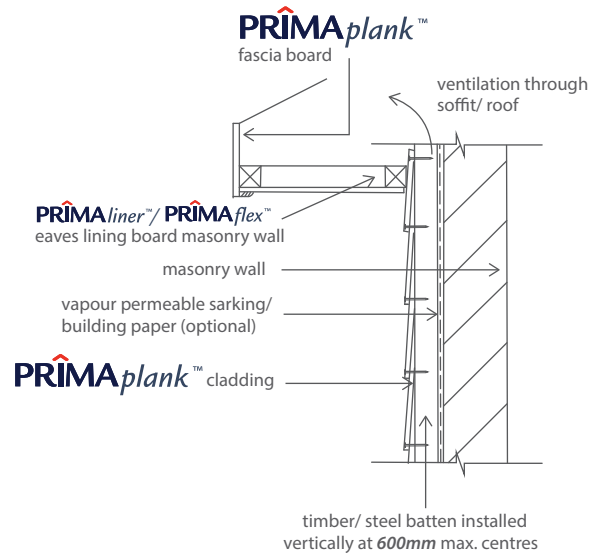

Figure 21: Wall ventilation detail

5 Fascia Board Introductions

5.1 General

PRIMAplank™ superior durability makes it a perfect choice for **fascia board** around the roof perimeter. With the choice of 'smooth' and 'woodgrain' texture, PRIMAplank™ fascia board is not only aesthetically pleasing but also cost effective.

5.2 Support

PRIMAplank™ fascia board is normally fixed to **timber** or **metal rafters/trusses** with spacing not exceeding **600mm centres**. When support spacing exceeds **600mm**, provide a continuous **battening** behind the fascia board. Alternatively, a **'dummy' rafter/truss** should be provided as intermediate support. The use of **9mm thick** plank is highly recommended when support spacing is more than **600mm centres**.

5.3 Installation

Apply a minimum of **2 fasteners** at each rafter or truss end. Drive fastener **12mm** from plank edge and **50mm** from corner.

Fix a **metal angle capping** at ends of metal **rafters/trusses** to facilitate PRIMAplank™ fascia board installation as described in **Figure 23**.

Fixings of attachment (such as **bracket** for **gutter**) to fascia board must be connected to the **roof structural element**.

5.4 Joints

Planks can be jointed with **PVC jointer** or **Butt Jointed**. Provide **3mm** gap if joint is to be sealed. These jointing options are shown in **Figure 22 & 23**. When **Off-support Joint** without **PVC jointer** is preferred, provide additional **metal/ timber backing** piece behind the fascia board. Ensure planks are secured to the **backing piece**. Hold **backing piece** firmly while driving the **fasteners**.

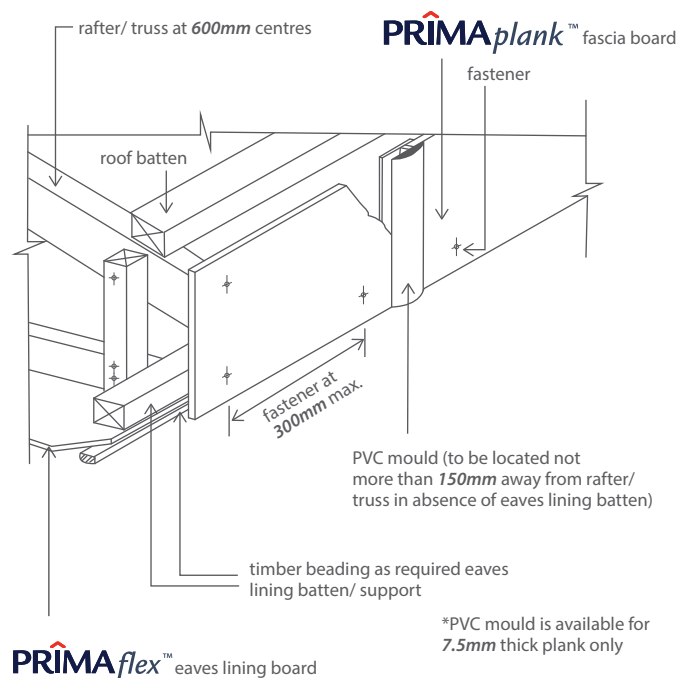

Figure 22: PVC joint (Timber frame)

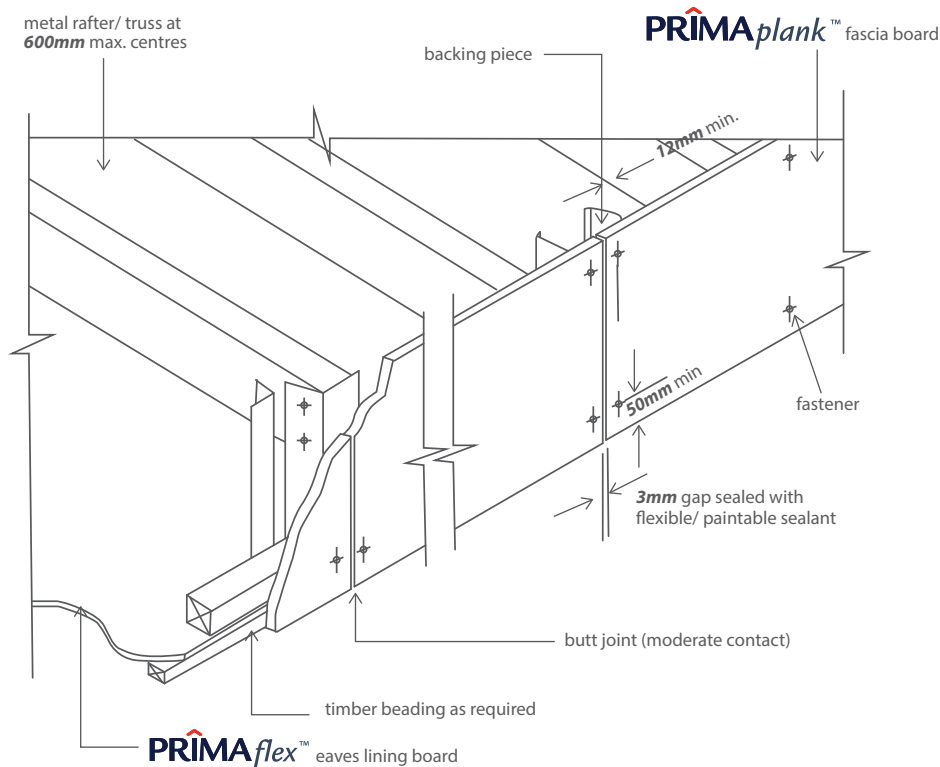

Figure 23: Butt joint & sealant (Metal rafter/ truss)

6 Decorative Fencing

6.1 General

PRIMAplank™ can be incorporated in the construction of conventional **masonry, timber** or **steel** framed fencing for medium to high-end terrace houses as well as semi-D or bungalows. **9mm PRIMAplank™** is recommended for this application.

6.2 Framing Requirement

Framing durability must satisfy the minimum requirement of the intended use. It is recommended to use **exterior grade (treated timber)** or **steel hollow section** to form the support. **Steel hollow section** must be suitably coated to resist external weather.

6.3 Installation

PRIMAplank™ can be installed **vertically** or **horizontally**. In any case, support must be provided at **400mm centres maximum**. Install fasteners approximately **30mm** from edge and **50mm** from corner of plank. Fix at least **2 fasteners** at each support.

PRIMAplank™ ends must not overhang (cantilever) more than 100mm from the support.

The following fasteners are suitable if it is desired to have screw heads exposed:-

- Timber Support: Use **No.10 x 30mm Hexagon head, Type 17** point screws
- Steel support: Use **No.10 x 25mm Hexagon head, self-drilling point screws**

Refer to screw **manufacturer's instruction** on the minimum screw penetration to framing member:

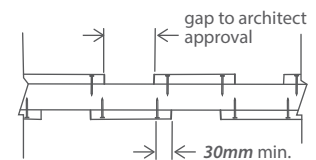

Horizontal Section

PRIMAplank™ fencing applied vertically

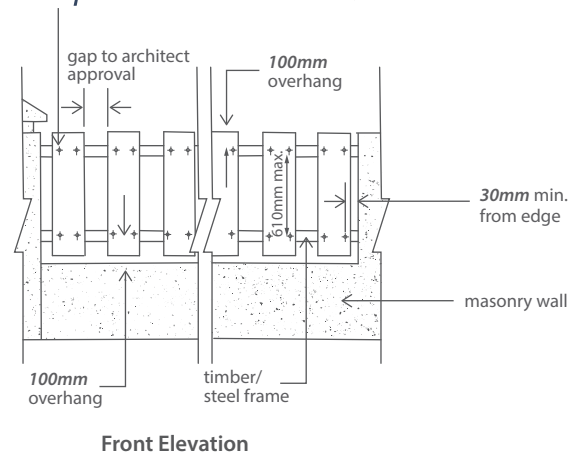

Front Elevation

Figure 24: Vertical fencing

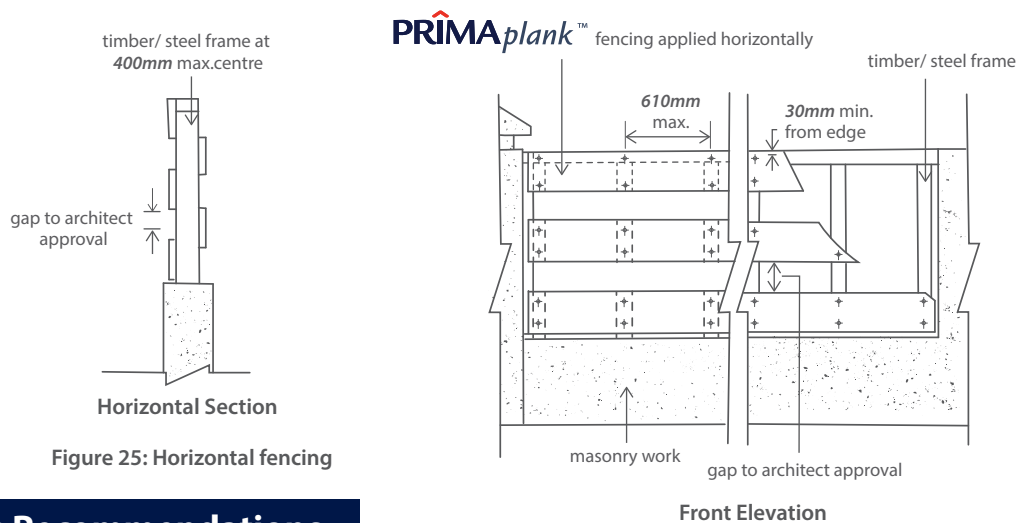

Figure 25: Horizontal fencing

7 Finishes Recommendations

Under normal circumstances **PRIMAplank™** must be coated within **3 months** after installation. For best result, decorate **PRIMAplank™** with **2 coats** of **100% quality acrylic paint**. For general-purpose applications, there is no requirement for **primers** or **sealers**. Ensure planks are **dry prior to painting**. For decorative fencing application, plank must be coated on both surfaces and all edges. All plank exposed surfaces and edges must be painted.

Semi-transparent stains and **shellac/varnish** are generally formulated for wood and not suitable for fibre cement products.

In all cases, coating manufacturer's recommendations must be strictly adhered to.

8 Working Instructions

8.1 Cutting

Cutting must be carried out in a well-ventilated area using one of the following methods:-

- **Score and Snap** - Score the plank face with 'score and snap'. Repeat until depth reaches 1/3 of plank thickness. Snap plank upward to achieve clean break. Trim cut edge with rasp if necessary.

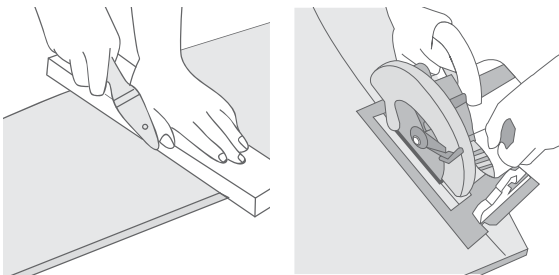

Figure 26: Score and Snap Method (left), Machine Cut (right)

8.2 Hand Saw

The use of fine-toothed hand saw coupled with quick jabbing action will normally produced best result.

8.3 Power Tool

When large amount of plank cutting is involved, use power cutting tool equipped with carbide-tipped or diamondtipped circular saw.

Drilling

Small holes can be formed using high-speed (HSS) drill bits. Larger circular holes can be created by drilling a series of small holes around the perimeter of the proposed hole, and gently tapping out the waste piece. Smoothen the rough drilled edge with rasp if necessary.

Handling & Storage

PRIMAplank™ must be stacked on flat ground and supported wpth level bearers prior to installation. Ensure all timber bearers of a stacked plank are aligned with other stacks. Improper plank stacking may result in permanent plank deformation that causes unsightly appearance such as waviness.

PRIMAplank™ must always be kept dry, preferably stored under a protected shade. When stored outdoors, it must be protected from water ingress and weather by covering with tarpaulin sheet. Allow wet plank to dry to equilibrium under a natural ventilated condition prior to installation.

To minimize breakages, **PRIMAplank™** must be carried with up-right.



WARRANTY

Hume Cemboard Industries Sdn Bhd ("the Company") warrants that it will at all times ensure that the products referred to herein ("the Products") shall be supplied by it to the purchaser free of any manufacturing defects and defective materials used in their manufacture.

In the event and if contrary to this assertion the Products prove to be defective, whether as a result of manufacturing defects or arising from the Company's use of defective materials, the Company will supply replacement Products. The Company shall, however, have the option and may choose to reimburse the purchaser the purchase price of the Products instead. The Company shall not be liable for any economic or consequential losses arising from any use of defective Products.

This warranty shall be void unless the purchaser has, in its handling and installation of the Products, complied with the recommendations contained in this brochure and other good building practices expected of a reasonable purchaser.

ADVISORY NOTE

Successful installations of Hume Cemboard Industries Sdn Bhd's Products depend on a large number of factors that are outside of the scope of this brochure. Particular design, detail, construction requirements and workmanship are beyond the control of the Company. As such, Hume Cemboard Industries Sdn Bhd's warranty does not extend to non-usability of Products or damage to Products arising from poor or defective designs or systems or poor quality of workmanship in the installation of Products.

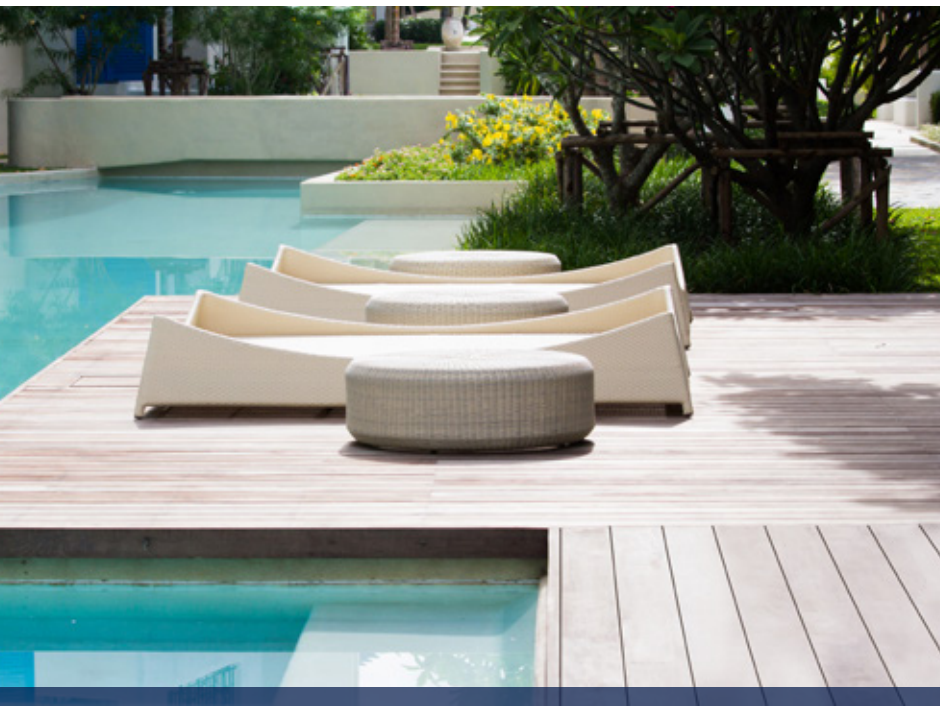

For more information, please contact us at:

Hume Cemboard Industries

A Member of the Hong Leong Group

No. 12 Jalan Tandang, 46050 Petaling Jaya, Selangor, Malaysia.

Malaysia Sales Tel: + 603 7625 9999 Fax: +603 7625 7822 Email: sales@humeceboard.com.my

Oversea Sales Tel: + 603 7625 3880 Fax: +603 7625 3990 Email: exportHCl@humeceboard.com.my

www.primafibrement.com